

Internal and Marginal Fit of Modern Indirect Class II Composite Inlays

Philipp C. Pott¹, Agnieszka Rzasa¹, Meike Stiesch¹, Michael Eisenburger¹

¹ Department of Prosthetic Dentistry and Biomedical Materials Research, Hannover Medical School, Hannover, Germany

Received 7 May 2014 and Accepted 20 June 2014

Abstract

Introduction: This *in vitro* study investigates the marginal and internal fit of indirect class II composite restorations. Two different processes for chair-side restorations were compared. In group A, the restorations were fabricated using CAD/CAM technology (Cerec, Sirona, Germany, Bernsheim) and in group B they were made by hand (GrandioSO Inlay System, VOCO GmbH, Germany, Cuxhaven). **Methods:** For a metal tooth with a MOD cavity each 10 restorations were made for groups A and B. For each restoration, a replica of the cement-gap made from light body silicone was produced by placing the restoration into the cavity of the metal tooth. For this purpose, a special restoration-positioning machine was developed. Each replica was sectioned off in the longitudinal axis (L) and in the cross axis (C). The thickness of the replicas was measured in both directions, using picture analysis software under a light reflection microscope. To evaluate the fit of the restorations, a special fitting parameter was calculated. Statistical analysis was performed with the t test. **Results:** The fitting-parameter in group B (L: $97.6\mu\text{m}\pm 73.0\mu\text{m}$; C: $71.8\mu\text{m}\pm 46.4\mu\text{m}$) was significantly lower than that of group A (L: $155.1\mu\text{m}\pm 102.3\mu\text{m}$; C: $168.2\mu\text{m}\pm 91.9\mu\text{m}$) ($P<0,001$). **Conclusions:** Within the limitations of this in-vitro study hand-made composite restorations using the GrandioSO Inlay System seems to be a good alternative to CAD/CAM production. The clinical success of these restorations has to be evaluated in further studies.

Key words: CAD/CAM, indirect composite restoration, internal fit, manual manufacturing, marginal fit.

Pott PC, Rzasa A, Stiesch M, Eisenburger M. Internal and Marginal Fit of Modern Indirect Class II Composite Inlays. J Dent Mater Tech 2014;3(3):99-105.

Introduction

Conservation of tooth structure has become an important strategy in modern dentistry (1,2). Small defects can be restored with composite or with ceramic restorations (3). Composite is suitable to fill small cavities. The bigger the cavity, the bigger is the effect of polymerization shrinkage. This polymerization shrinkage in direct restorations is a well described problem (4,5), and is a persistent challenge (6). Alternatively, all-ceramic restorations can be used to restore missing tooth substance and to reduce the effect of polymerization shrinkage, which is limited to small layer of composite cement. All-ceramic restorations can be produced manually by a technician or by CAD/CAM technology. Handmade restorations need more time than do CAD/CAM restorations and demand the practical skills of a technician. CAD/CAM technology is a well-established method to process materials such as ceramics, metal and resin. Depending on the material and the size of the restoration, the time between the scanning process and the completion of the restoration can be very short. However, this process has some disadvantages: a complete armamentarium is needed, including a scanner, a computer with the relevant software and a milling unit. Furthermore, it is necessary to have various materials in stock, e.g. different types of ceramics in different colors. Last but not least, a dentist or technician is required who has sufficient experience of working in CAD/CAM processes.

Another way to reduce the effects of polymerization shrinkage is the extra-oral indirect production of composite restorations. This procedure and its potential problems have been discussed in the literature since the 1980s (7-10). In recent years, indirect composite restorations have attracted increasing interest as an alternative for all-ceramic restorations again, especially in the field of pediatric dentistry (11,12).

For indirect construction of composite restorations, a plaster-model or an intraoral scan for CAD/CAM is typically necessary. The impressions are normally taken with silicone. A new special system using alginate impressions in combination with a model silicone (GrandioSO Inlay System, VOCO GmbH, Cuxhaven, Germany) may be a cheap and timesaving alternative for indirect composite restorations.

The present study compared the internal and marginal fit of indirect class II composite restorations made with two different methods: handmade restorations with the above mentioned new system and CAD/CAM restorations (CEREC, Sirona, Bernsheim, Germany).

Materials and Methods

To simulate the clinical situation an artificial upper first molar (AG 3, Frasaco, Germany, Tettngang) was mounted into a model (standard working model AG3, Frasaco, Germany, Tettngang). With a milling machine, a mould for an MOD-inlay was prepared with preparation-angles of 6°. To produce a stable master tooth, the acrylic tooth was duplicated and cast in metal (Phantom-Metal NF, Degudent, Germany, Hanau). It was necessary to construct a machine which allows the reproducible positioning of the restoration into the

MOD cavity of the metal tooth. The metal tooth was embedded into an aluminum mould using this machine, which consists of two functional parts: a clamp at the base and a movable cross head on which two fixations pins for the restoration were mounted via a 2D-hinge. This machine is shown in Fig. 1.

In group A (n=10), restorations were produced by CAD/CAM technology (Cerec, Sirona, Germany, Bernsheim). In group B, the GrandioSO Inlay System (VOCO GmbH, Germany, Cuxhaven) for extra-oral manufacturing of composite restorations was used.

In group A, the original tooth was prepared with a special scan-spray for every new specimen (zfx zircon scan, Xiondental, Germany, Munich), in order to reduce light reflection effects. After that, the surface was scanned by a 3D-camera (InEos, Sirona, Germany, Bernsheim) and a digital model of the tooth was calculated by special software (Cerec, Sirona, Germany, Bernsheim). After defining the margins of the cavity, the software submits a proposal of a CAD-design of the restoration. Then, the restorations were milled with a digital preset spacer for the cement gap of 50 µm (InLab MC XL, Sirona, Germany, Bernsheim) out of composite blocks (CAD Temp Monocolor CT-40, Vita Zahnfabrik, Germany, Bad Säckingen).

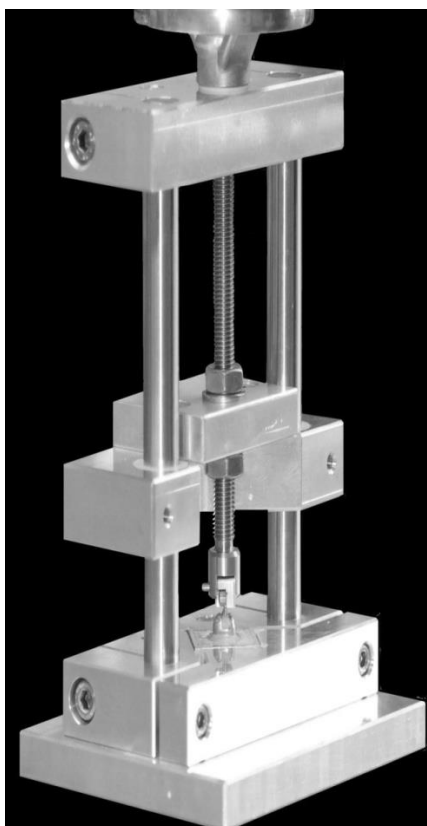

Figure 1. Specially developed restoration-positioning machine

In group B (n=10), alginate impressions of the original tooth were taken (Alginoplast fast, Heraeus Kultzer GmbH, Germany, Hanau) and filled up with model silicone material (Modellsilikon, VOCO GmbH, Germany, Cuxhaven). The inlays were produced in a horizontal layering technique, following the manufacturer's instructions. At first, a basic layer of composite material (GrandioSO, VOCO GmbH, Germany, Cuxhaven) was placed in the cavity and cured. Half of the remaining cavity was filled up in the next step. Finally, the restoration was completed and removed with caution from the silicone model. The individual layers did not exceed the thickness of 2.0 mm, and were polymerized for 20 seconds.

All specimens in group A and B were adapted to the cavity of the metal tooth.

The original tooth was fixed in the positioning machine. Each inlay was placed in the metal tooth and the cross head of the machine was lowered until the pins touched the inlay. The inlay was fixed with flowable composite (Tetric flow, Ivoclar Vivadent, Germany, Ellwangen) on the pins. This procedure allowed the removal of all inlays parallel to the long axis of the tooth. The cavity was filled up with a light body silicone (Detaseal bite, DETAX, Germany, Ettlingen) and the restoration was repositioned into the cavity. After the silicone had set, the restoration was removed from the tooth. The silicone replica of the cement gap then adhered to the inlay, as the surface of the composite was rougher than the surface of the metal tooth (Fig. 2).

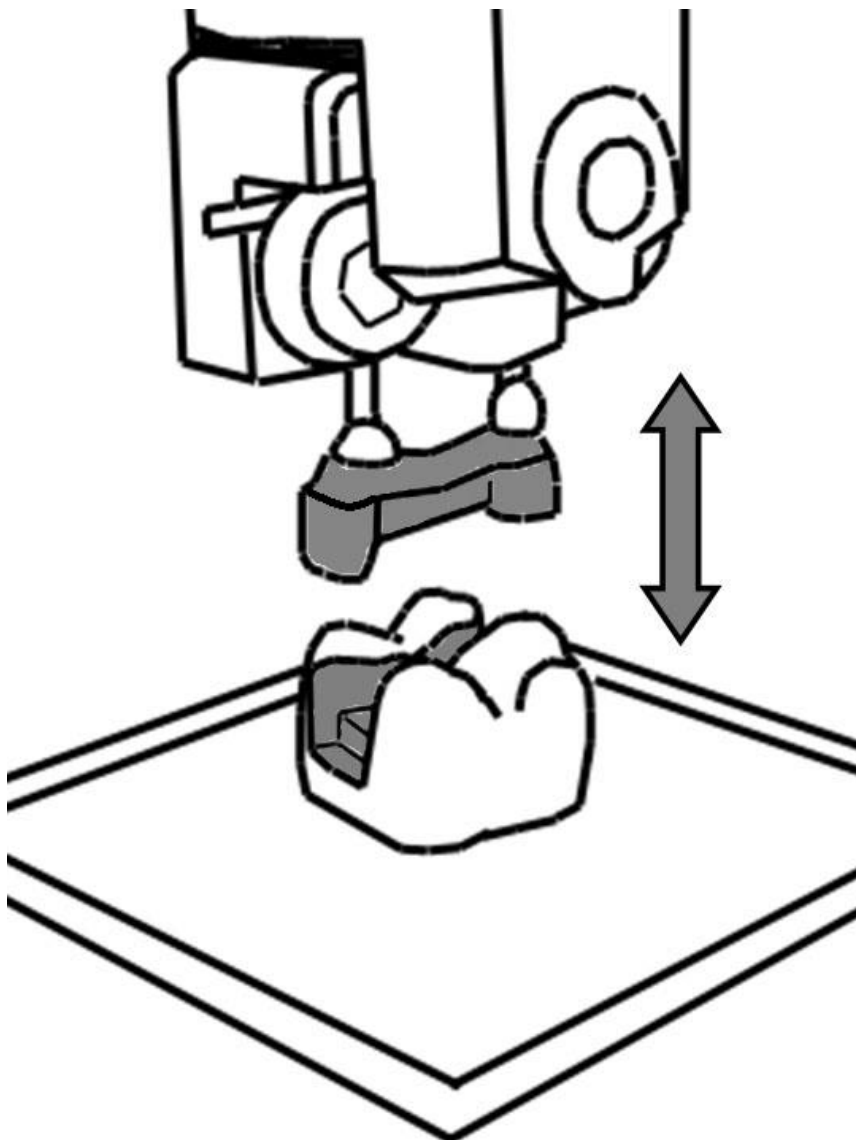

Figure 2. Positioning-technique of the restoration into the corresponding cavity

The tooth was removed from of the positioning machine and a plastic box was fixed in the clamp. The box had two pairs of slots for a razor blade. These channels were placed opposite each other on either side of the box. Before the restoration was positioned in the plastic mould, the mould was filled up with a medium body silicone material (Dimension Garant L, 3M Espe, Germany, Seefeld). After the silicone was set, the composite restoration was removed. The replica of the cement gap adhered to the medium body silicone. The remaining volume was filled up with the medium body silicone: thus the replica of the cement gap was embedded completely. The silicone block was cut into four parts with a razor blade.

Figure 3 shows the defined measuring points (Fig. 3). The thickness of the cement gap replica was measured at right angles to the tooth surface, except at points Q3, Q5, L3, L5, L7 and L9. These points were located at the points of inflection of the cavity. Therefore, the thickness of the replica was measured along the bisecting line of the adjacent tooth surfaces.

To make the measurement, two lines AB and BC had to be defined in the border zone between the yellow stabilization silicone and the purple replica. The bisecting line angle between AB and BC was drawn. The distance was measured between the intersections of the bisecting line and the replica (DE) (Fig. 3). High resolution photographs were taken from the silicone blocks of each specimen using a reflected light microscope. Measurements were performed with the image analysis software Image Access V09.4 (Imagic Bildverarbeitung AG, Switzerland, Glattbrugg).

Because of the variation in the measurements within the groups, a fitting parameter was calculated for each single restoration. Fitting parameters were defined as the mean of all the measurements in each specimen, once in the longitudinal axis and once in the cross axis. This was necessary due to the variation in the position of each composite restoration in the tooth. Within the groups, the mean overall fitting parameters were calculated for both directions. Statistical analysis was performed with t test.

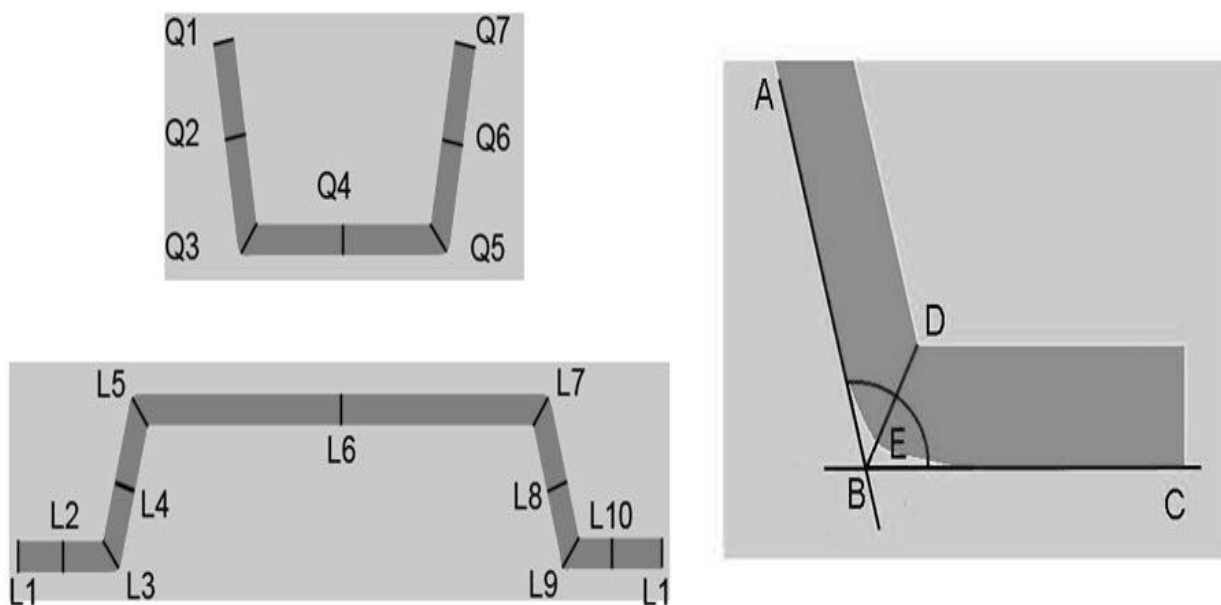

Figure 3. Localisation of measuring points (left) and construction of the measuring points Q3, Q5, L3, L5, L7 and L9 (right)

Results

In group A, the measured thickness of the silicone replicas of the cement gap was 370.6 μm as maximum and 0.0 μm as minimum. The mean fitting parameter was 155.1 μm ±102.3 μm in the longitudinal axis and 168.2 μm ±91.9 μm in the cross-axis. In group B, the maximal thickness of the replica was 362.0 μm : the

minimal thickness was 0.0 μm . The fitting parameter was 97.6 μm ±73.0 μm in the longitudinal axis and 71.8 μm ±46.4 μm in the cross axis (Table 1). Manually produced restorations (group B) had significantly lower fitting parameters in both directions than did the CAD/CAM-restorations (group A) ($P < 0.001$) (Fig. 4).

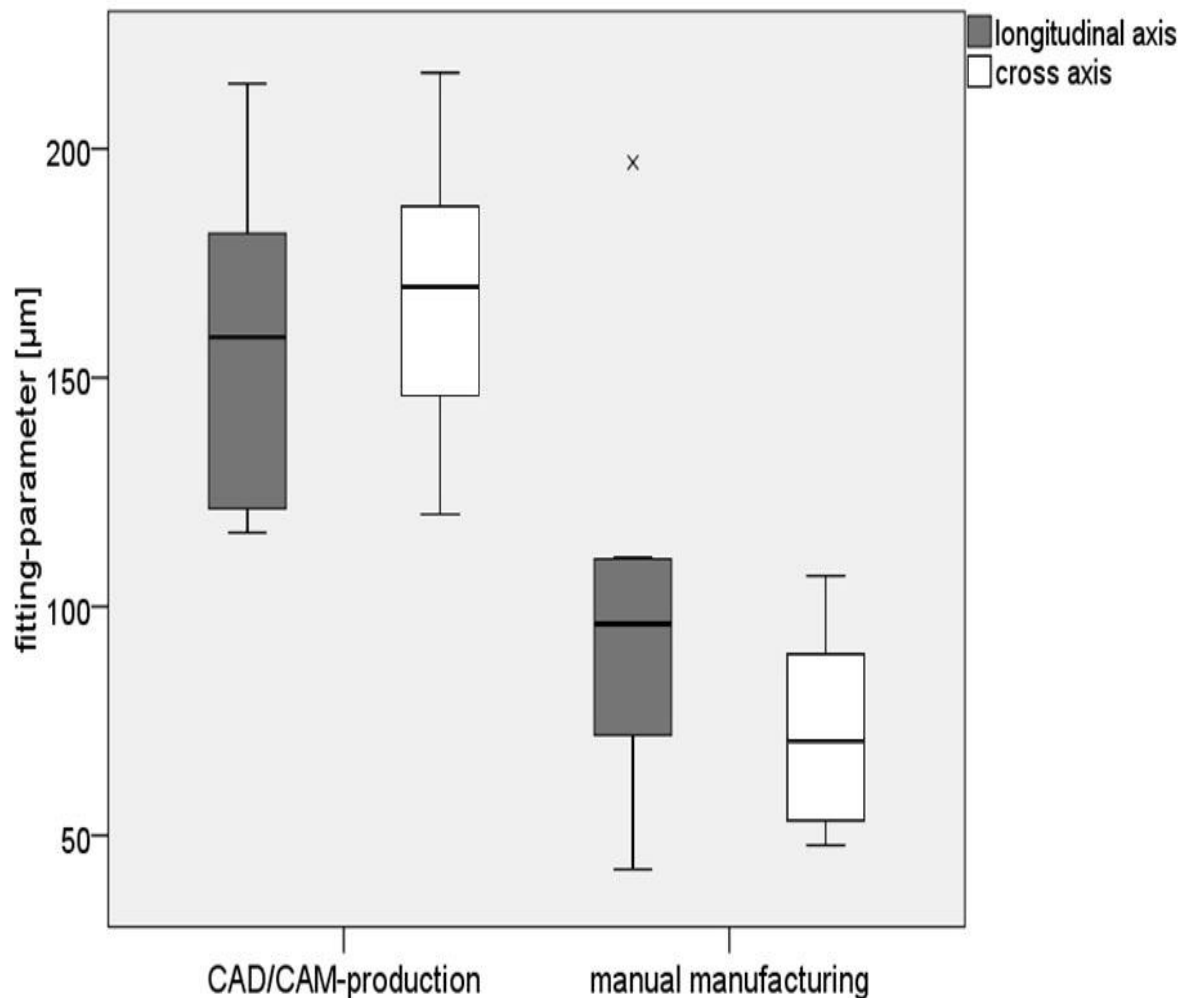

Figure 4. Boxplot of the fitting-parameters in longitudinal axis and in cross axis

Table 1. Fitting-parameter, standard deviation, maximum and minimum of the measured thickness of cement-gap-replica in longitudinal-axis and cross-axis of all data

		Group A	Group B
Production technique		CAD/CAM	manual manufacturing
longitudinal axis	fitting parameter	155.1 ± 102.3 µm	97.6 ± 73.0 µm
	maximum	370.6 µm	362.0 µm
	minimum	0.0 µm	0.0 µm
cross axis	fitting parameter	168.2 ± 91.9 µm	71.8 ± 46.4 µm
	maximum	362.2 µm	362.0 µm
	minimum	0.0 µm	0.0 µm

Discussion

The data suggested that the fit of the group B restorations is considerably better than for group A. There were some differences between the two groups during the manufacturing process and these influenced the width of the cement gap between restoration and tooth. In group A, these factors were the precision of the digital scan (13) and the thickness of the scan-spray-

layer, the preset space for the cement gap during the milling process and the precision of the milling process itself. Hamza et al. (14) showed that the fit of CAD/CAM restorations depended on the CAD/CAM - system and material. In group B, the precision of the alginate impression, the silicone model and the skill of the operator may influence the fit of the restorations. Within the limitations of this study, it is not possible to

evaluate the effects of these factors. Therefore, further research is necessary.

In this study, the mean fitting parameters were $97.6\mu\text{m}\pm 73.0\mu\text{m}$ (longitudinal axis) and $71.8\mu\text{m}\pm 46.4\mu\text{m}$ (cross axis) after manual manufacture of the restorations in silicone models in group B. After the CAD/CAM production of the restorations, the parameters were $155.1\mu\text{m}\pm 102.3.0\mu\text{m}$ in the longitudinal axis and $168.2\mu\text{m}\pm 91.9\mu\text{m}$ in the cross-axis. Literature addressing to the fit of indirect composite restorations is very rare. However, the findings of this study coincide with the results of other researchers. Price and Gerrow (15) evaluated the marginal gaps of indirect composite restorations and found spaces between $149.5\mu\text{m}\pm 107.4\mu\text{m}$ and $53.9\mu\text{m}\pm 48.3\mu\text{m}$. Gemalmaz and Kükrer (16) showed that the proximal marginal fit of class II ceromer inlays was $67.0\mu\text{m}$ *in vitro*. Hanning et al. (17) found marginal gaps between 280 μm and 350 μm for laboratory finished composite inlays. The relatively large variation in the measurements may originate from two factors: The first factor is the position of the restoration in the cavity. As the inlays had clearance over the tooth, the restoration may be slightly displaced in the horizontal plane when it is fixed at the pins in the restoration-positioning machine, resulting in perforation of some replicas with a thickness of 0.0 μm . In this case, corresponding measurements at the opposite side were high (A = 370.6 μm , B= 362.0 μm). The second reason for the variation is the individual customization of each specimen to achieve a clinically adequate fit for each restoration in the original metal tooth. All of the restorations were produced and customized by the same dentist, who evaluated the fit optically and by feeling after the manufacturing process. If the restoration did not fit into the cavity, interference points were removed using a rotating diamond bur. This procedure simulated clinical practice. If interferences had to be removed, the cement-gap at these special localizations was larger than in the other areas. These interferences were documented. If it was necessary to remove interference points several times during the customization process at the same location, the restoration fractured or the restoration was rated as clinically unusable, the restoration was discarded and a new restoration was produced.

In summary, manual manufactured class II composite restorations using the GrandioSO Inlay System seem to be a clinical sufficient alternative to CAD/CAM restorations. The available studies indicate that the long-term stability of these restorations cannot be guaranteed (18).

Conclusion

Within the limitations of this in-vitro study, the following conclusions can be drawn:

Handmade indirect composite restorations showed better marginal and internal fit than CAD/CAM restorations.

Manual manufacturing of indirect composite restorations using the GrandioSO Inlay System (VOCO GmbH, Germany, Cuxhaven) seems to be a good alternative to direct composite restorations to reduce the polymerization shrinkage.

Manual manufacturing of indirect composite restorations using the GrandioSO Inlay System (VOCO GmbH, Germany, Cuxhaven) seems to be a good alternative to CAD/CAM restorations, as they have better internal and marginal fit, with better cost and time efficiency.

Further studies are still needed to evaluate clinical long-term stability more precisely.

Acknowledgement

This study was supported by VOCO GmbH, Germany, Cuxhaven. There is no conflict of interest.

References

1. Tassery H, Levallois B, Terrer E, et al. Use of new minimum intervention dentistry technologies in caries management. *Aust Dent J* 2013;58:40-59.
2. Walsh LJ, Brostek AM. Minimum intervention dentistry principles and objectives. *Aust Dent J* 2013;58:3-16.
3. Zaruba M, Kasper R, Kazama R, et al. Marginal adaptation of ceramic and composite inlays in minimally invasive mod cavities. *Clin Oral Investig*. 2014;18:579-87.
4. Mantri SP, Mantri SS. Management of shrinkage stresses in direct restorative light-cured composites: a review. *J Esthet Restor Dent* 2013;25:305-13.
5. Garcia D, Yaman P, Dennison J, Neiva G. Polymerization shrinkage and depth of cure of bulk fill flowable composite resins. *Oper Dent* 2014;39:441-8.
6. Bortolotto T, Guillaume D, Gutemberg D, Veuthey JL, Krejci I. Composite resin vs resin cement for luting of indirect restorations: comparison of solubility and shrinkage behavior. *Dent Mater J* 2013;32:834-8.

7. Robinson PB, Moore BK, Swartz ML. Comparison of microleakage in direct and indirect composite resin restorations *in vitro*. *Oper Dent* 1987;12:113-6.
8. Plasmans PJ, van't Hof MA, Creugers NH. Fabrication times for indirect composite resin restorations. *J Dent* 1992;20:27-32.
9. Cassin AM, Pearson GJ. Microleakage studies comparing a one-visit indirect composite inlay system and a direct composite restorative technique. *J Oral Rehabil* 1992;19:265-70.
10. Cetin AR, Unlu N, Cobanoglu N. A five-year clinical evaluation of direct nanofilled and indirect composite resin restorations in posterior teeth. *Oper Dent* 2013;38:E1-11.
11. Koyuturk AE, Ozmen B, Tokay U, Tuloglu N, Sari ME, Sonmez TT. Two-year follow-up of indirect posterior composite restorations of permanent teeth with excessive material loss in pediatric patients: a clinical study. *J Adhes Dent* 2013;15:583-90.
12. Perugia C, Ferraro E, Docimo R. Immediate dentin sealing in indirect restorations of dental fractures in paediatric dentistry. *Eur J Paediatr Dent* 2013;14:146-9.
13. Schaefer O, Decker M, Wittstock F, Kuepper H, Guentsch A. Impact of digital impression techniques on the adaption of ceramic partial crowns in vitro. *J Dent* 2014;42:677-83.
14. Hamza TA, Ezzat HA, El-Hossary MM, Katamish HA, Shokry TE, Rosenstiel SF. Accuracy of ceramic restorations made with two CAD/CAM systems. *J Prosthet Dent* 2013;109:83-87.
15. Price RB, Gerrow JD. Margin adaptation of indirect composite inlays fabricated on flexible dies. *J Prosthet Dent* 2000;83:306-13.
16. Gemalmaz D, Kükrer D. *In vivo* and *in vitro* evaluation of marginal fit of class II ceromer inlays. *J Oral Rehabil* 2006;33:436-42.
17. Hanning M, Prieshoff T, Albers HK. Accuracy of fit and margins of laboratory-finished SR-Isosit composite inlays. *ZWR* 1990;99:544-8.
18. Hellwig E, Klimek J, Schmidt C. Primary accuracy of fit of composite inlays produced according to the indirect method. *Dtsch Zahnärztl Z* 1991;46:148-51.

Corresponding Author:

Philipp-Cornelius Pott
 Department of Prosthetic Dentistry and Biomedical Materials Research
 Hannover Medical School
 Carl-Neuberg Str. 1
 30625 Hannover, Germany
 E-Mail: Pott.Philipp-Cornelius@mh-hannover.de